

# Stadco Top Dog™ Generators

Ideal for Top Mounted Installations

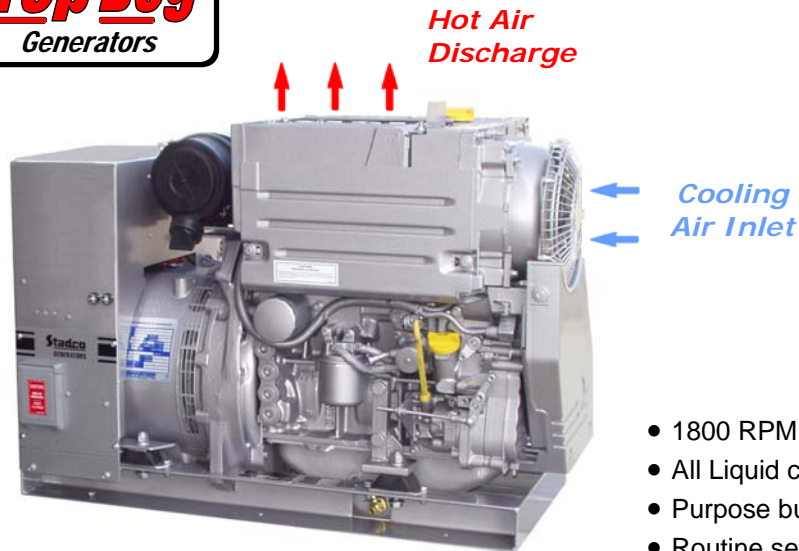

Model TD12, TD20, TD25

**10.0 KW - 25.0 KW  
Diesel Generators**

Field Proven Performance  
For Mobile, Open Air & Free  
Standing Applications

**Industrial Quality  
in a Compact Package**

**Design Features:**

- 1800 RPM diesel with 4-pole AC Alternator.
- All Liquid cooled diesel engines.
- Purpose built for vehicle applications.
- Routine service items located exclusively on the service side.
- 500 Hour Lube oil change interval on TD versions
- Electronic Engine Control and protection system virtually eliminates catastrophic failure events.
- **Guaranteed to meet NFPA 1901-2 hr. Load test requirement.**

- \* Shipped with #1556 Remote Control Panel w/12Ft. Control cord. See Bulletin #S112.
- \* Dimensions may change without notice.
- \* (1) Dimension changed 10/06

**\* NFPA 1901  
Compliant \***

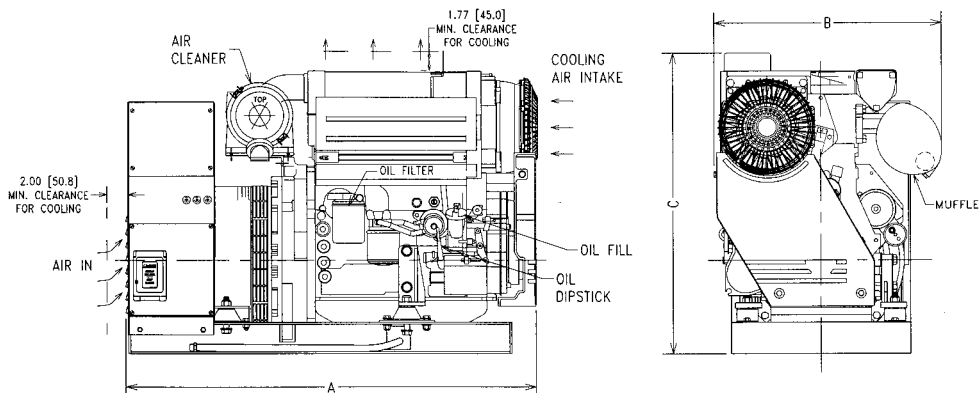

\* Features may vary depending on model. Drawing is representative of TD12, TD20 & TD25. See sales drawings for actual details.

Connects to vehicle fuel tank & battery.	Installed Dimension	Top Dog Diesel Generators - 1800 RPM			
		TM10 / 10KW	TD12 / 12KW	TD20 / 20KW	TD25 / 25KW
	A	37.5"	33.8"	38.8"	44.0"
	B	18.8"	21.5"	21.5"	20.6"
	C	27.9"	29.6"	28.6"	28.6"
	Approx. weight	524 lbs.	650 lbs.	785 lbs.	850 lbs.