

Stadco Cellpac™ Generators

NEW BREED OF COMPARTMENT GENERATOR

♦ for Vehicle Compartments & Enclosures ♦



High Performance Stadco Cellpac™ Generators operate with compartment doors closed.



Cellpac™ Model CP7

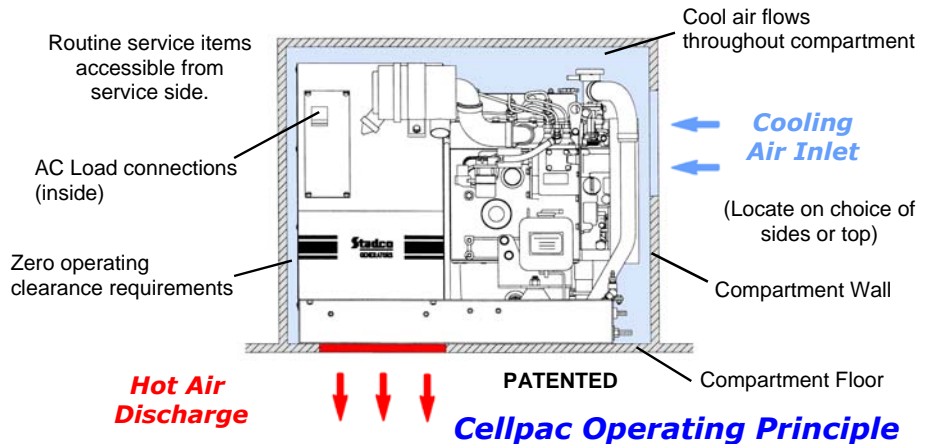

Design Features:

- 1800 RPM diesel with 4-pole AC Alternator.
- Purpose built for vehicle compartment applications or enclosures.
- Cool compartment operation - with doors closed. No air ducts required.
- Zero installation clearance requirements.
- Routine service items located exclusively on the service side.
- Electronic engine control system. Provides push-button start/stop plus 4-Function engine safety protection.
- **Guaranteed to meet NFPA 1901-2 hr. Load test requirement.** *

PATENTED **CELLPAC™ SUPER COMPACT - DIESEL • 6 - 25 KW**

- * Shipped with #1556 Remote Control Panel w/12Ft. Control cord. See Bulletin #S112
- * Dimensions may change without notice.
- * Features may vary depending on model.
- * (1) Dimension changed 10/06.

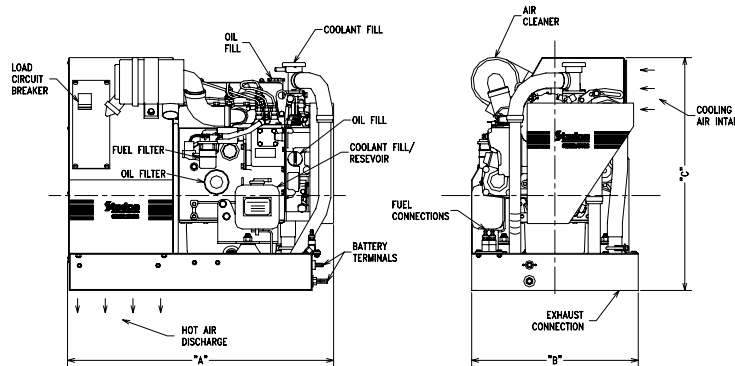

*** NFPA 1901 Compliant ***



Connects to vehicle fuel tank & battery.	Installed Dimension	Cellpac Diesel Generators - 1800 RPM					
		CP6 / 6KW	CP7 / 7KW	CP10 / 10KW	CP15 / 15KW	CP20 / 20KW	CP25 / 25KW
	A	28.8"	30.6" (1)	32.4"	38.0" (1)	39.4" (1)	46.6" (1)
	B	18.0"	18.0"	19.5"	19.5"	19.5"	20.3"
	C	25.1"	25.1"	26.7"	26.8"	28.3"	28.1"
	Approx. weight	420 lbs.	440 lbs.	540 lbs.	655 lbs.	750 lbs.	860 lbs.

Stadco Top Dog™ Generators

Ideal for Top Mounted Installations

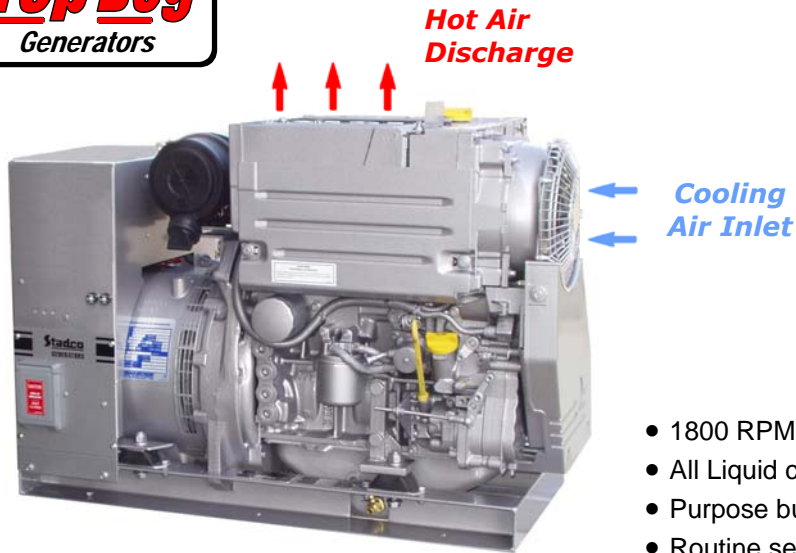

Model TD12, TD20, TD25

**10.0 KW - 25.0 KW
Diesel Generators**

**Field Proven Performance
For Mobile, Open Air & Free
Standing Applications**

**Industrial Quality
in a Compact Package**

Design Features:

- 1800 RPM diesel with 4-pole AC Alternator.
- All Liquid cooled diesel engines.
- Purpose built for vehicle applications.
- Routine service items located exclusively on the service side.
- 500 Hour Lube oil change interval on TD versions
- Electronic Engine Control and protection system virtually eliminates catastrophic failure events.
- **Guaranteed to meet NFPA 1901-2 hr. Load test requirement.**

- * Shipped with #1556 Remote Control Panel w/12Ft. Control cord. See Bulletin #S112.
- * Dimensions may change without notice.
- * (1) Dimension changed 10/06

*** NFPA 1901
Compliant ***

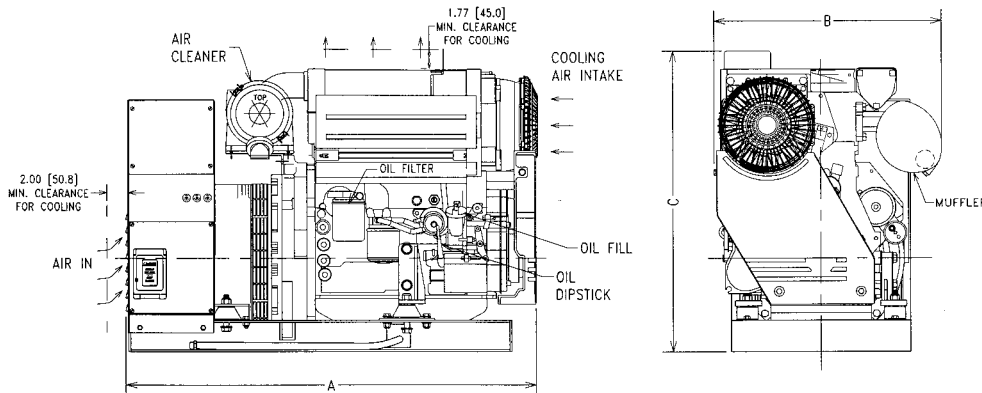

* Features may vary depending on model. Drawing is representative of TD12, TD20 & TD25. See sales drawings for actual details.

Connects to vehicle fuel tank & battery.	Installed Dimension	Top Dog Diesel Generators - 1800 RPM			
		TM10 / 10KW	TD12 / 12KW	TD20 / 20KW	TD25 / 25KW
	A	37.5"	33.8"	38.8"	44.0"
	B	18.8"	21.5"	21.5"	20.6"
	C	27.9"	29.6"	28.6"	28.6"
	Approx. weight	524 lbs.	650 lbs.	785 lbs.	850 lbs.