

FUEL TANK CONSTRUCTED OF STEEL OR ALUMINUM  
MINIMUM 75 GAL. CAPACITY

NOTE: W/ RDV INJECTION PUMPS  
FUEL GALLERY PRESSURE = 5.0 BAR (72.5 PSI.)

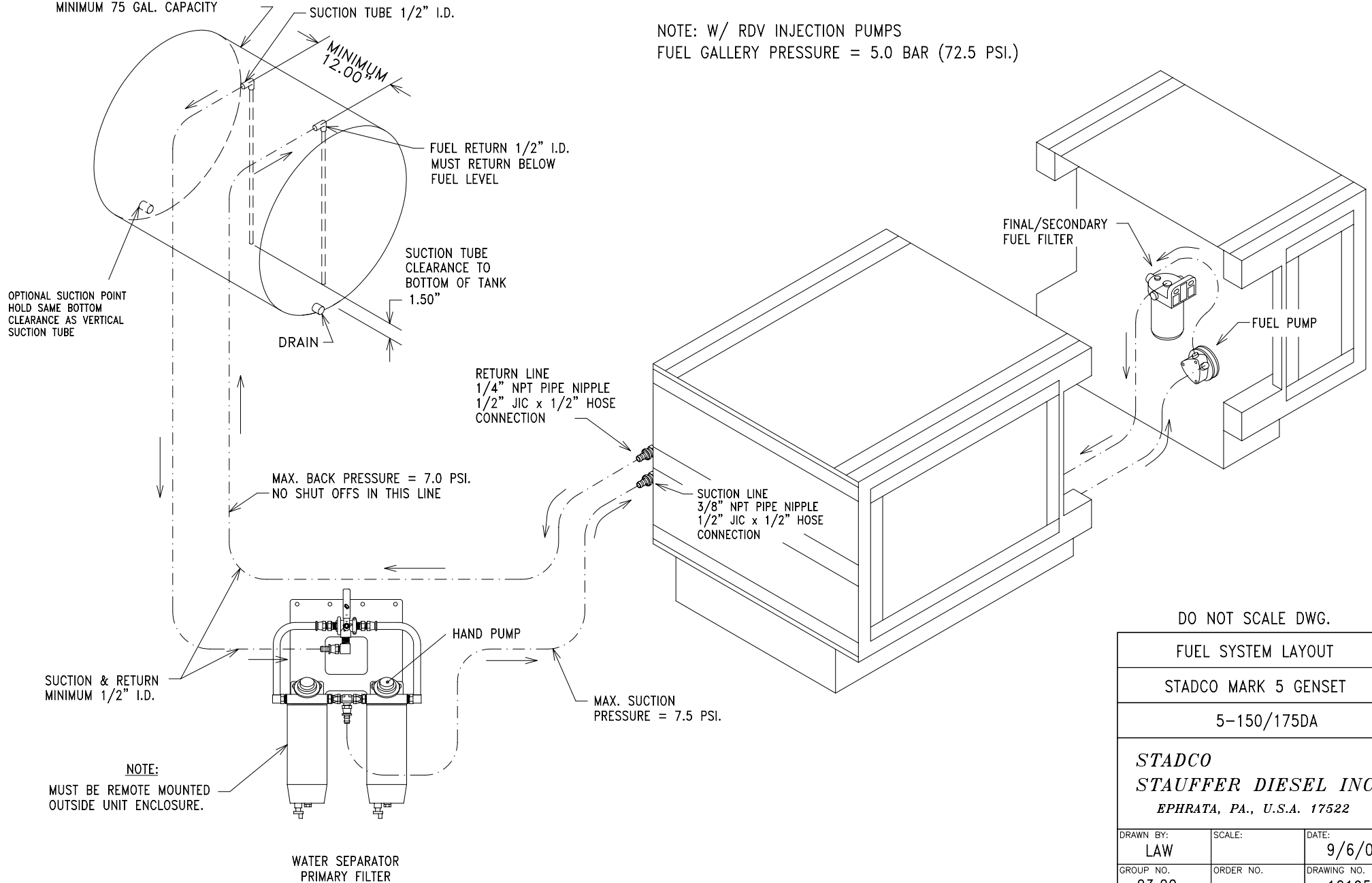

DO NOT SCALE DWG.

FUEL SYSTEM LAYOUT

STADCO MARK 5 GENSET

5-150/175DA

**STADCO**  
**STAUFFER DIESEL INC**  
EPHRATA, PA., U.S.A. 17522

DRAWN BY: LAW	SCALE:	DATE: 9/6/00
GROUP NO. 23.20	ORDER NO.	DRAWING NO. 12195